

东莞日昇进出口有限公司

## DONGGUAN SUNRISE IMPORT & EXPORT CO.,LTD

ADD: No. 6, Chongwen Lane 4, Xiang Wei, Dalang Town, Dongguan City, Dongguan City, Guangdong, CHINA

<https://www.sunrisedg.com> Email: [Jesslin123@163.com](mailto:Jesslin123@163.com) WeChat /Whatsapp : +86 159 9271 9785

### Single Wing Package Drop Tester

**Model: SR-604S**

#### Summary:

The machine is widely used to test a variety of products packaged in the handling or transportation to test the caused damage inside the product, and for the prevention of pesticide in advance, can use the machine to be tested is expected to arrive the best solution, so as to minimize transit losses, and to assess the impact of electronic components dropping resistance by the strength in the handling; packaging containers Ling, angle, surface reliability of the equipment.



#### Features:

- 1.Unique swing arm mechanism design, swing arm break away from acceleration more than 3 G/SEC.
- 2.With double column guide and hydraulic buffer absorb residual swing arm force, movements smooth, reliable, low noise.
- 3.Damping screw lifting mechanism, preventing drop institution unexpectedly glide.

4. Pneumatic automatic chain, preventing swing arm unusual break away.
5. Extensible support bracket and baseboard.

### Test Standards:

#### Both Single swing and Double swing meet the following standards

- ISO 2248-1985 packaging - vertical impact drop test for full and complete transport packaging,
- GB/ t48575-92 drop test method for packaging transport packaging,
- JIS Z0202-1994 drop test method for packaging goods

### Specifications:

Model	Single Wing Package Drop Tester	
Dropping height range	300~1500mm	300~2000mm
Display	Digital display / Digital height indicator (optional)	
Drop model	Free drop	
Height accuracy	≤2% of the setted value	
Maximum load	80kg	
Test space (LxWxH)	1000x1000x1000mm	
Angle tolerance	≤5°	
motor	1/2HP	
Dimension (WxDxH)	1200*1700*2360	1200*1700*2750
Weight	About 390kg	About 480kg
Power supply	AC380V 50Hz or specified by user, compressed air 0.5~0.7Mpa	

Test Standards

ISO2248-72(E) GB/T4857.5 JISZ0202-87 IEC68-2-27

Different models can be chosen



#### Single swing model: SR-604S

1. Drop height: 300~1500mm
2. Base plate size : 1200\*1700mm
3. Reset mode : Electric reset
- 4. Suitable sample: Regular packaging, like box**
5. Stable performance : 98%
6. Sample max load : 80kg
7. Sample max size : 1000\*1000\*1000mm
8. Sample plate size : 180\*180\*10mm
9. Power supply : 380V (or customized)
10. Machine weight : about 390kg

#### Double swing model: SR-604D

1. Drop height : 400~1500mm
2. Base plate size : 1400\*1200mm
3. Reset mode : manual reset
- 4. Suitable sample: soft package, like gunny bag**
5. Stable performance: 90%
6. Sample max load : 70kg
7. Sample max size : 800\*800\*800mm
8. Sample plate size : 700\*350mm\*10mm (2 pieces)
9. Power supply : 380V (or customized)
10. Machine weight : about 330kg

Different color you can choose





Single swing model details

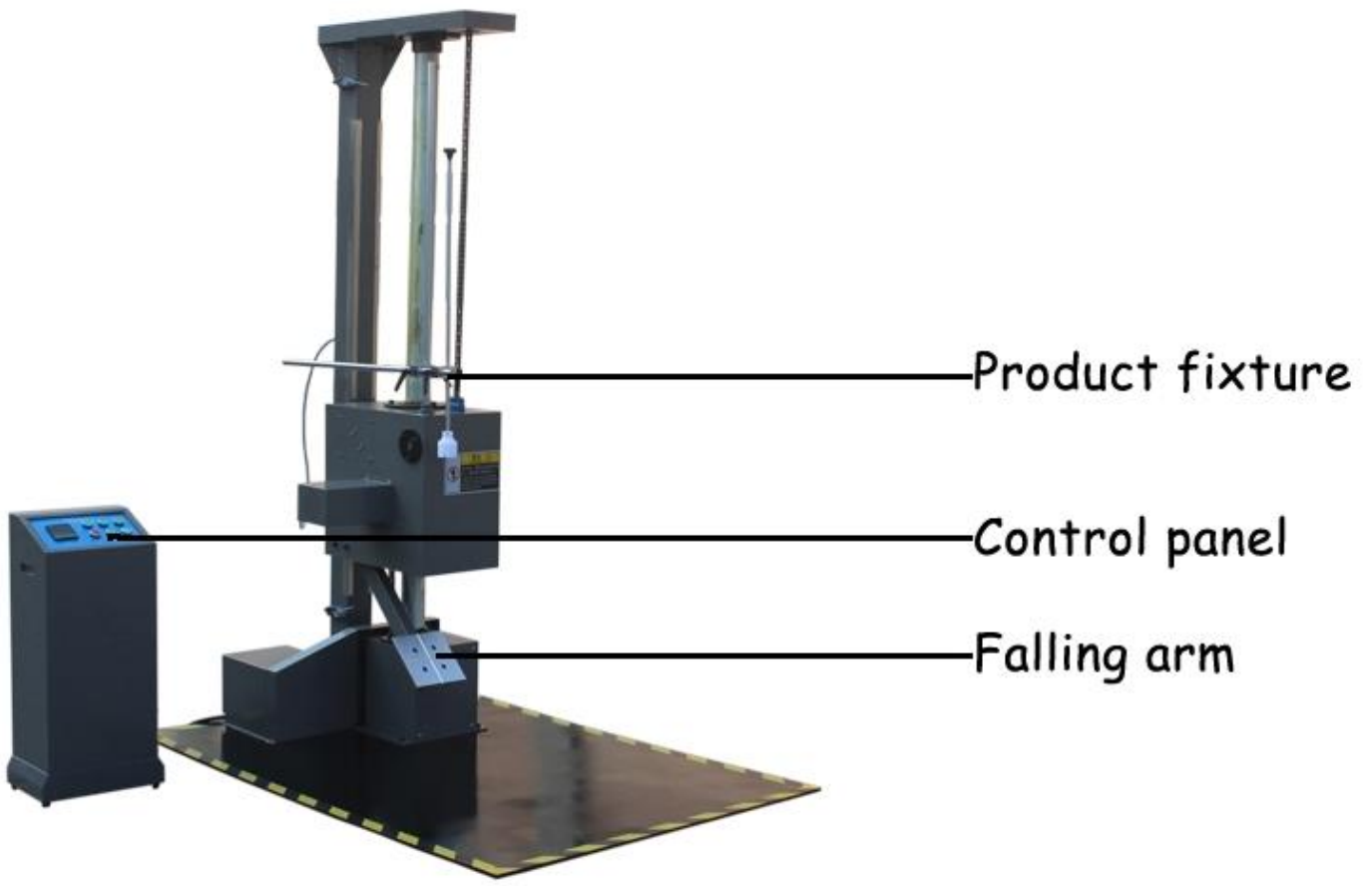

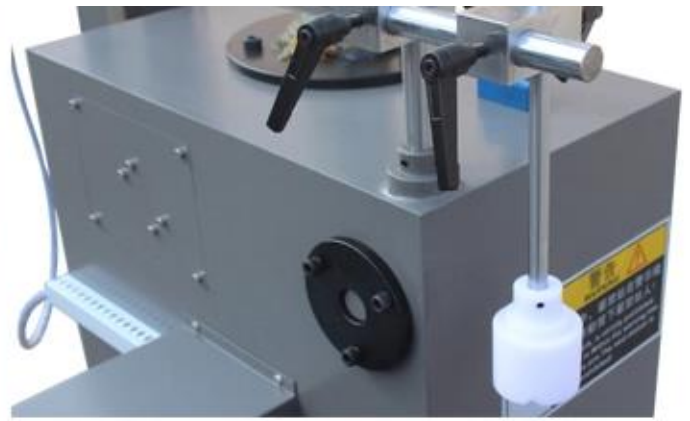

Double swing model details

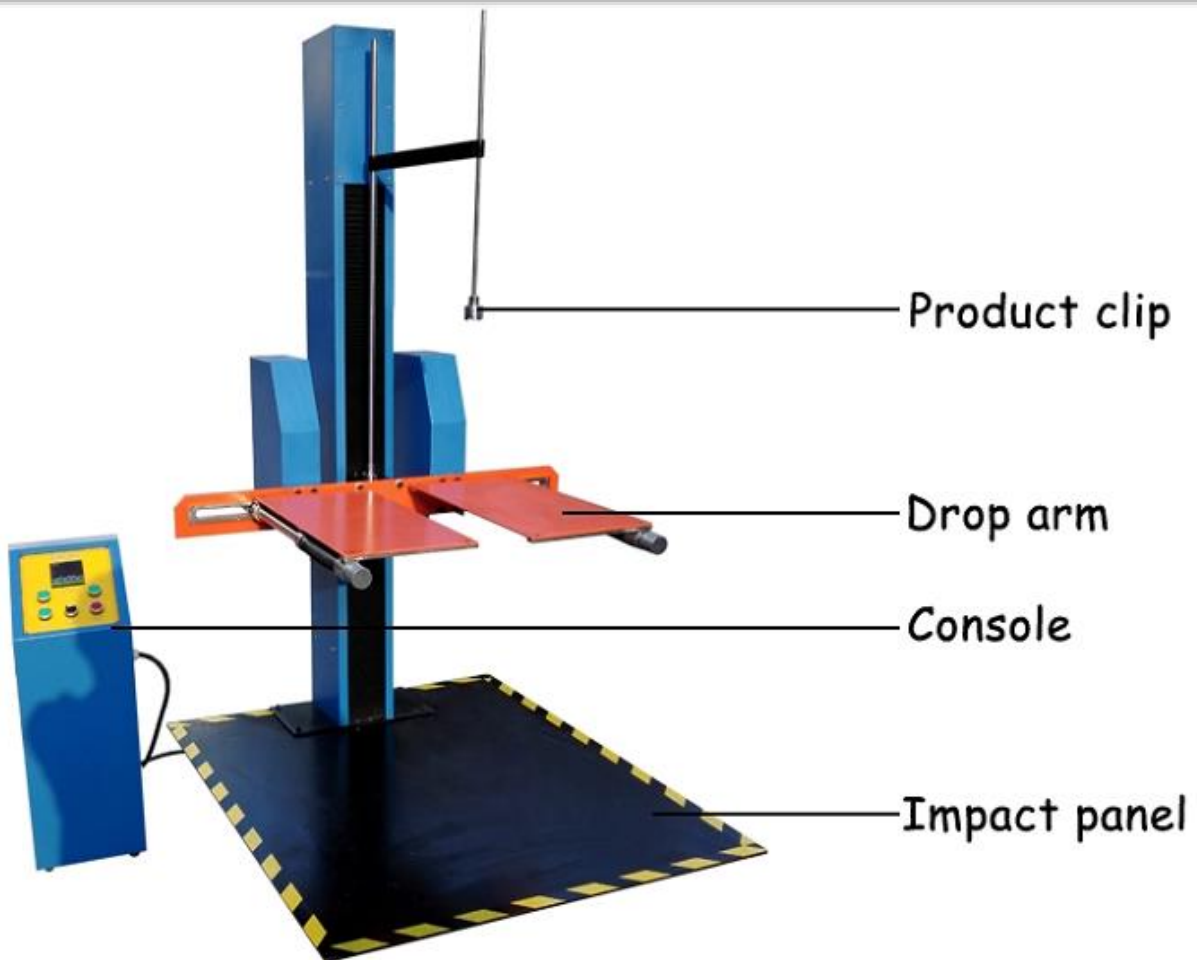



Different colors can be chosen

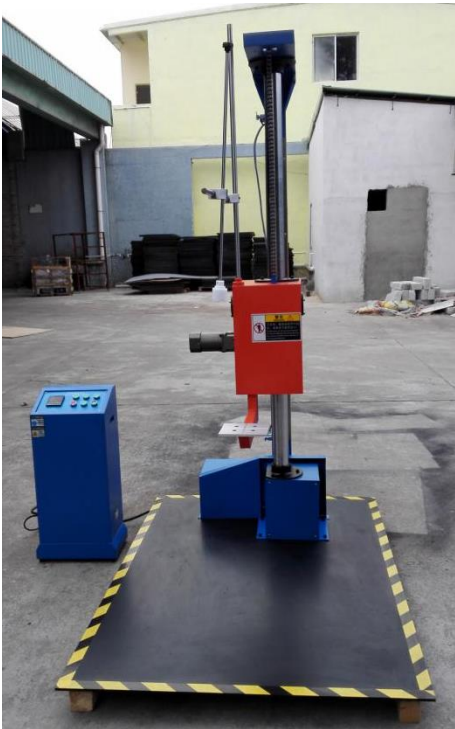



## *After-sales Service*



- 1) 12 months product warranty. Free components will be provided if any performance failure occurs within 12 months caused by non-human damage.
- 2) If you face any problems in future during testing process, We will serve as a technical adviser for lifetime, give you a reply within 48 hours and the solution provided within 3 working days.
- 3) We will provide some guidance for the normal use of the machine, and in the case of the machine is not used for a long time, protection guidance provided, then keep the good performance of the machine.
- 4) We can offer operation video and operation manual, also can provide video-conference.
- 5) If necessary, on-site service will be provided, but the transport and travel expense shall be borne by customer.

## SUNRISE Factory

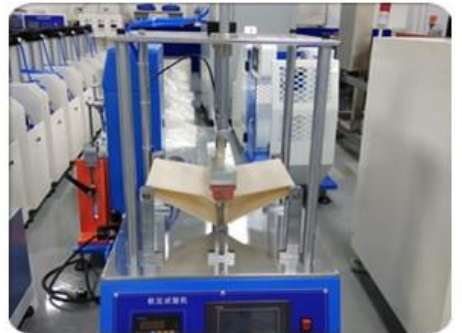

SUNRISE has the equipment and experience, own R&D and consultant team to meet and exceed your testing requirement. Many of the test equipment we ship to customer include tailor-made features to exactly fit the application customer wants.

We have professional packaging teams and shipping forwarder to pack and deliver your products safely!

1. Out packing: Standard export wooden case.
2. Inner packing: With careful stretch film wrap products, hard wood board + strong bandage to fix corners.
3. Checking teams: Specialized staff to inspect and classified your goods.

